

Planning to Ramp-up?

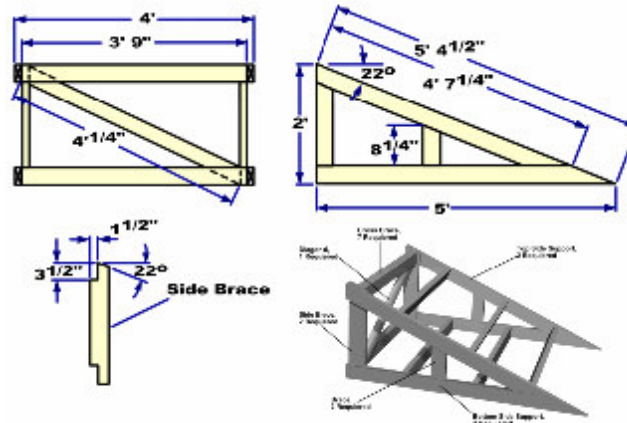

Planning = Success

When ramping up or ramping down a contact center, planning gives the foundation required for stability and success. Masterson is dedicated to understanding your needs through planning and experience. We start by learning more about your center, your agents and of course your staffing needs. We find out the personalities you desire and the skills you require. We have the capability to benchmark the knowledge, skills and abilities as well as the personality traits and behaviors required for success. We then provide you with the *Right People™* to meet those needs.

Mobile Processes

Masterson has the capability to ramp up contact centers anywhere in the United States. With mobile offices and processes on the ready, we can be in place to ramp up a new contact center in a matter of days should the need arise; Providing you with *"The Right People, Right Away!"™*

Industry Leaders

Masterson Personnel is affiliated with the Call Center Networking Group (CCNG), the nation's largest association for contact center professionals. This affiliation ensures Masterson is familiar with emerging trends and technologies in the contact center industry.



**MASTERSON
PERSONNEL**
"The Right People, Right Away"™

www.mastersonpersonnel.com